

## Manipulator – 5 Function Rigmaster

### Alstrom-Schilling RigMaster Manipulator

The RigMaster by ALSTROM Schilling Robotics is a five-function, rate-controlled, heavy-lift grabber arm that can be mounted on a wide range of subsea remotely operated vehicle (ROVs). The grabber arm can be used to grasp and lift heavy objects or to anchor the ROV by clamping the gripper around a structural member at the work site. Constructed primarily of aluminium and titanium, the RigMaster delivers the power, performance and reliability required for this demanding work.

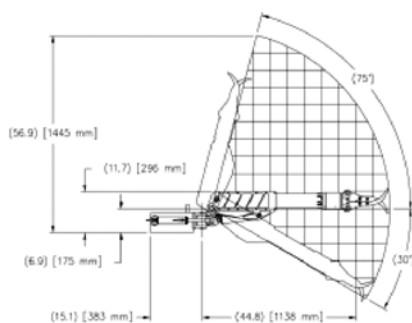
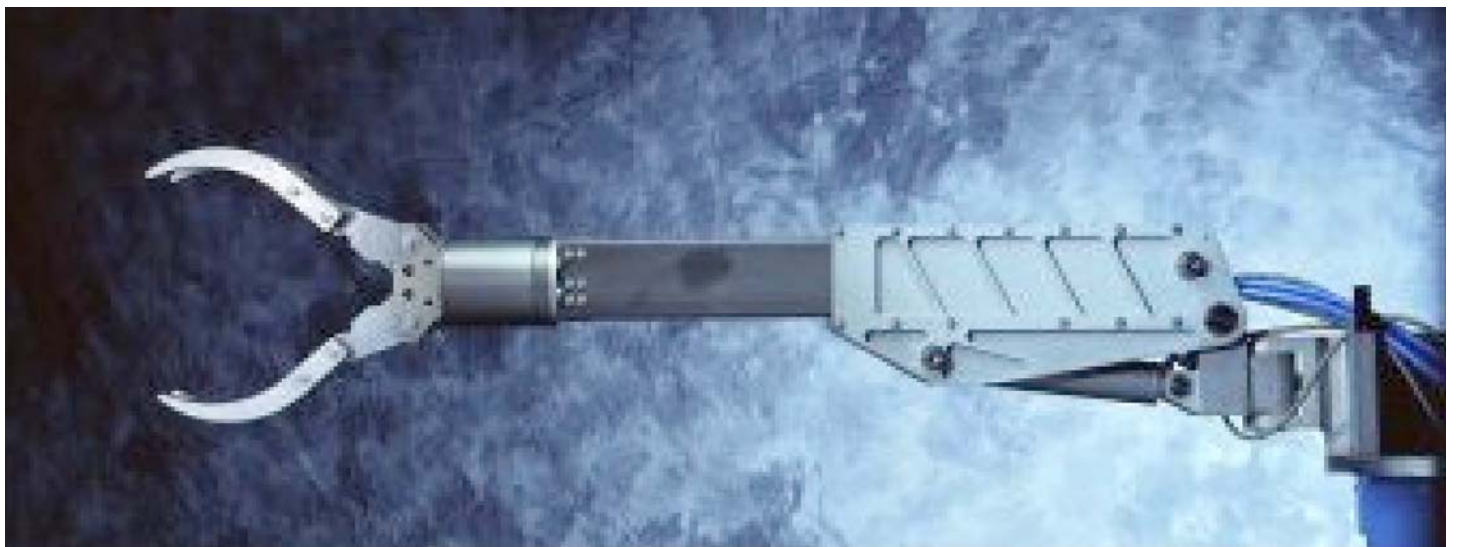

**Elevation View**  
1 Square = 5 inches (127mm)

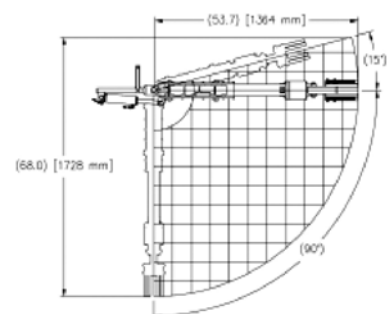

**Plan View**  
1 Square = 5 inches (127 mm)

