

Manipulator - 7 Function Titan III

Alstrom Shilling Titan III Manipulator

As the industry standard for dexterous manipulator systems for underwater applications, the TITAN 3 is extensively used on remotely operated vehicles (ROVs).

The seven-function TITAN 3 has the dexterity and accuracy necessary to perform the fine movements needed for complex tasks. When this ability is combined with the manipulator's reach (1,915 mm or 75.4 inches), payload capacity (113 kg at full extension), depth rating (available up to 6,500 msw), and large operating envelope, the TITAN 3 offers unequalled performance in a wide range of subsea applications.

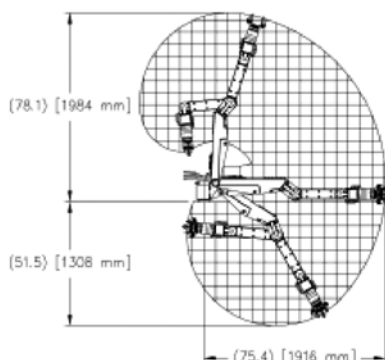

Elevation View
1 Square = 5 inches (127 mm)

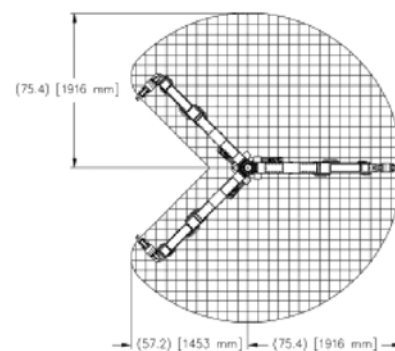

Plan View
1 Square = 5 inches (127 mm)

